



Department of Civil, Structural, and Environmental Engineering

SEESL Structural Engineering and Earthquake Simulation Laboratory SEESL

212 Ketter Hall, North Campus, Buffalo, NY 14260-4300

Fax: (716) 645-3733 Tel: (716) 645 5400 X 16

<http://www.nees.buffalo.edu>

Synchronizer Developers Manual

by

Jason P. Hanley
University at Buffalo

Report No. SEESL-2004-04

Version 1.0.0

University at Buffalo
Buffalo, New York
October 7, 2004

Structural Engineering

SEESL
Laboratory

Earthquake Simulation

Table of Contents

1. INTRODUCTION.....	3
2. DESIGN	3
3. BUILDING	4
4. AUTHORS.....	4
5. ACKNOWLEDGEMENTS.....	4
6. LICENSE.....	4

Table of Figures

Figure 1: Synchronizer Simulink Diagram.....	3
--	---

1. Introduction

This application is designed to base its clock off of a SCRAMNet interrupt (from MTS controllers) and output a clock signal based on this. It also outputs trigger signals based on trigger information from MTS controllers on SCRAMNet.

2. Design

The application is written in Simulink and generates code for xPC Target OS.

It reads clock and trigger information from SCRAMNet and outputs this via DIO lines on a NI I/O board.

A configuration file controls which devices to trigger from and which devices to send this trigger to. The configuration file also controls the rate at which the clock is output to the devices. This clock must be a multiple of 2 and less than 1024 since our reference clock operates at 1024 Hz.

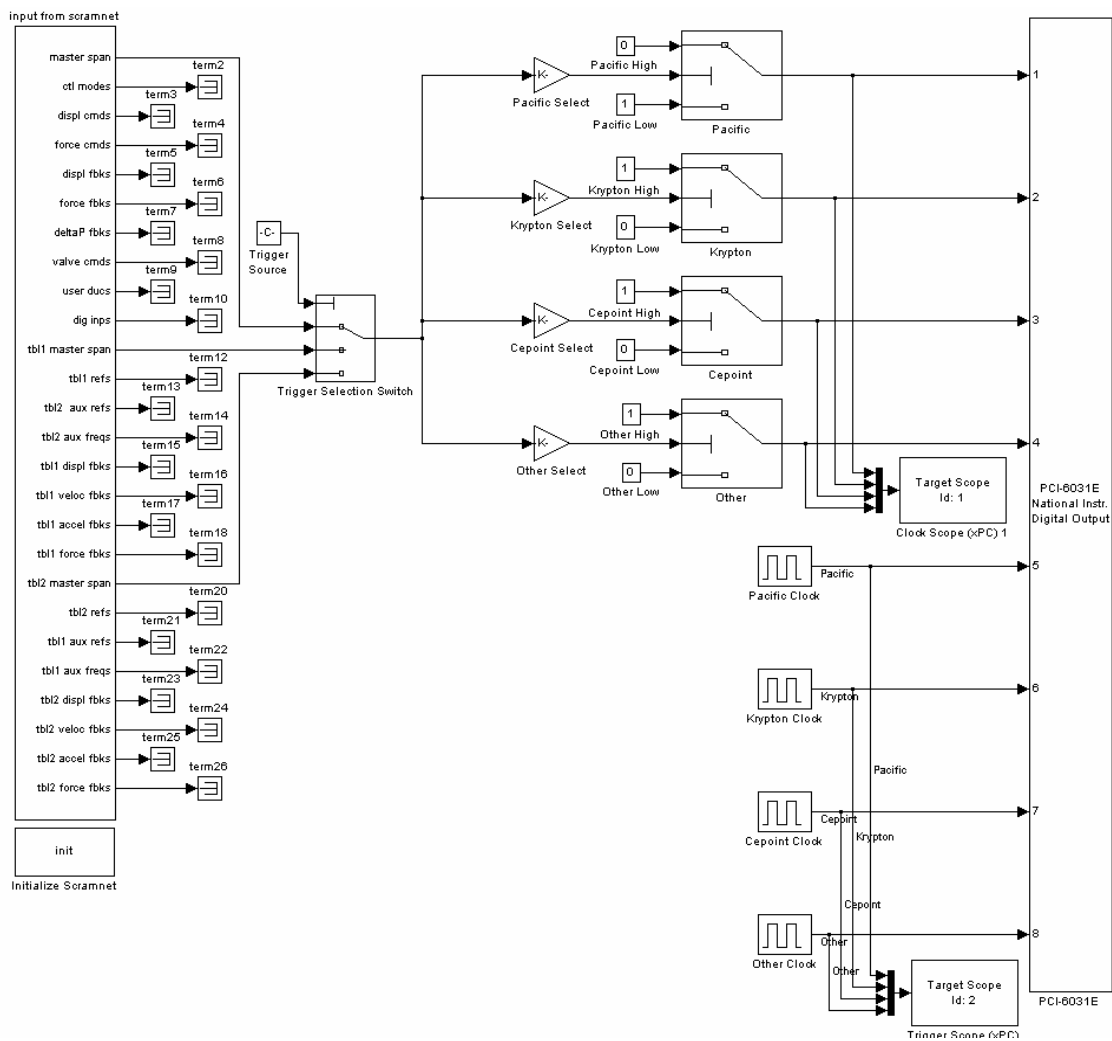

Figure 1: Synchronizer Simulink Diagram

3. Building

The application can be downloaded from here:
<http://nees.buffalo.edu/software/Synchronizer/>

See *Synchronizer Users Guide* for documentation on building and running the application.

4. Authors

Jason P. Hanley
University at Buffalo
email: jphanley@buffalo.edu
phone: (716) 645-2114 ext. 2450

This program is a modified version on the FastHybrid program provided by MTS.

5. Acknowledgements

This work is supported in part by the George E. Brown, Jr. Network for Earthquake Engineering Simulation (NEES) Program of the National Science Foundation under Award Numbers CMS-0086611 and CMS-0086612.

6. License

This software is released under the following license. This license is commonly known as the [MIT License](#).

Copyright (c) 2004 University at Buffalo

Permission is hereby granted, free of charge, to any person obtaining a copy of this software and associated documentation files (the "Software"), to deal in the Software without restriction, including without limitation the rights to use, copy, modify, merge, publish, distribute, sublicense, and/or sell copies of the Software, and to permit persons to whom the Software is furnished to do so, subject to the following conditions:

- The above copyright notice and this permission notice shall be included in all copies or substantial portions of the Software.

THE SOFTWARE IS PROVIDED "AS IS", WITHOUT WARRANTY OF ANY KIND, EXPRESS OR IMPLIED, INCLUDING BUT NOT LIMITED TO THE WARRANTIES OF MERCHANTABILITY, FITNESS FOR A PARTICULAR PURPOSE AND NONINFRINGEMENT. IN NO EVENT SHALL THE AUTHORS OR COPYRIGHT HOLDERS BE LIABLE FOR ANY CLAIM, DAMAGES OR OTHER LIABILITY, WHETHER IN AN ACTION OF CONTRACT, TORT OR OTHERWISE, ARISING FROM, OUT OF OR IN CONNECTION WITH THE SOFTWARE OR THE USE OR OTHER DEALINGS IN THE SOFTWARE.